

PERFORMANCE DATA SHEET NEMA PREMIUM NR CAN NEMA 12 - 12

Catalogue #: MPP-81

HP	kW	Voltage	S.F. @ 60Hz	EFF.	P.F.	Frame	Design	L.R. Amps
125	93,25	575	1,15	95,0%	0,92	444TS	B	726

60 Hz								Code	F.L. RPM
FLA									
208	230	416	460	480	575	600		G	3580
/	/	/	/	/	107,2	/			

50 Hz								Code	F.L. RPM
FLA			S.F. @ 50Hz	Efficiency	Power Factor				
190	380	415				/	/	/	/
/	/	/							

Wgt. Lbs	PH	Duty	Insul. Class	Amb.	Elevation	Temp. Rise° C
1247	3	Cont.	F	40°C	1000M (3300 Ft)	< 80

% Efficiency		% Power Factor		Torque		Winding Resist. Ω	Safe Cold Start (Secs)
Full Load:	95,0%	Full Load:	0,92	Full Load Ft/Lbs	183,4		
3/4 Load:	94,4%	3/4 Load:	0,90	Locked Rotor %	130		
1/2 Load:	93,8%	1/2 Load:	0,86	Break Down %	250		

Rotor Inertia Wk2 Lb-Ft2	Max Load Inertia Wk2 Lb-Ft2	Shaft Material	Frame Material	DE Bracket Type	ODE Bracket Type	Enclosure	NEMA Rating	Lead Wire Size
16,61	145	Standard	Cast Iron	Standard	Standard	TEFC	IP55	5AWG

Ball Bearings		Grease	Mount Type	Orientation	Paint	Sound Pressure @ 3FT	Sound Power
DE	ODE						
6314	6314	Mobil PolyrexEm	Rigid	Horizontal	Green	92	104

Inverter Duty. Motor meets MG1 parts 31.4.4.2	Constant Torque Range	Variable Torque Range	Constant HP RPM
		10:1	20:1

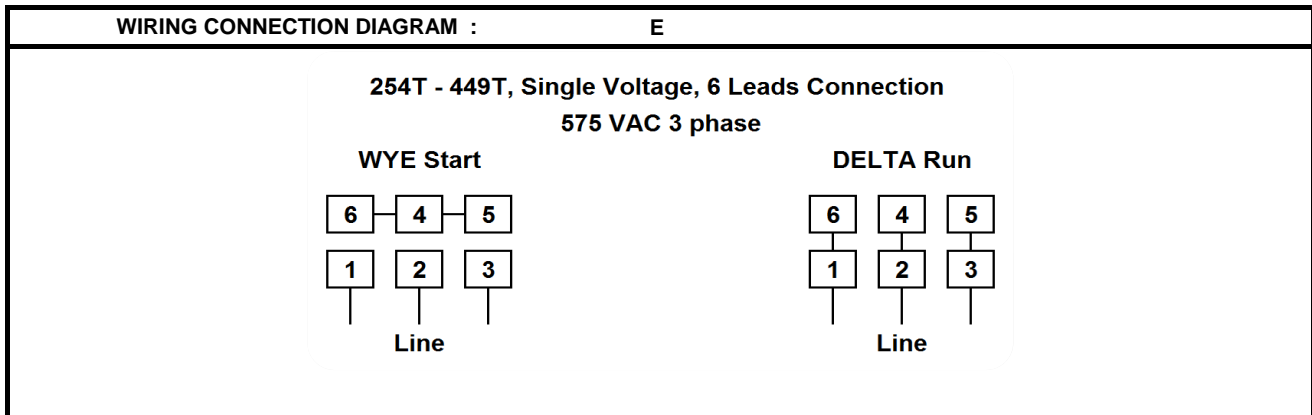

Date: 2020-02-27
 Customer: _____
 Contact: _____
 Submittee: J.C. Lavallée

Catalogue #: MPP-81

NEMA PREMIUM NR CAN NEMA 12 - 12										
HP	VAC	RPM	Enclosure	Frame	Frequency	Design	Poles	LR Code Letter	Insulation Class	Temp. Rise °C
125	575	3580	TEFC	444TS	60	B	2	G	F	< 80
	0Hz	6Hz	15Hz	30Hz	45Hz	60Hz	75Hz	90Hz	105Hz	120Hz
Amps	107,2	107,2	107,2	107,2	107,2	107,2	107,2	107,2	107,2	107,2
RPM	0	358	895	1790	2685	3580	4475	5370	6265	7160
Torq ft.lb	146,70	183,38	183,38	183,38	183,38	183,38	146,70	122,25	104,79	91,69
Peak Tq ft.lb	206,30	412,60	412,60	412,60	412,60	412,60	330,08	275,07	235,77	206,30
HP	0	12,5	31,3	62,5	93,8	125,0	125,0	125,0	125,0	125,0
	Locked Rotor	Pull-Up	Breakdown	Rated Load	Idle	Duty	S. F.	Ambient	Elevation	dBA @ 1M
Speed (RPM)	0,0	1512	2880	3580	3600	Continuous	1,15	40°C	3300 ft	92
Current (Amps)	726,0	617,1	432,0	107,2	26,9	VFD Rating: Meets MG1 parts 31.4.4.2				
Torque (ft-lbs)	238,4	178,8	458,4	183,4	0,0	C.T.	10:1	V.T.	20:1	

Motor Speed Data

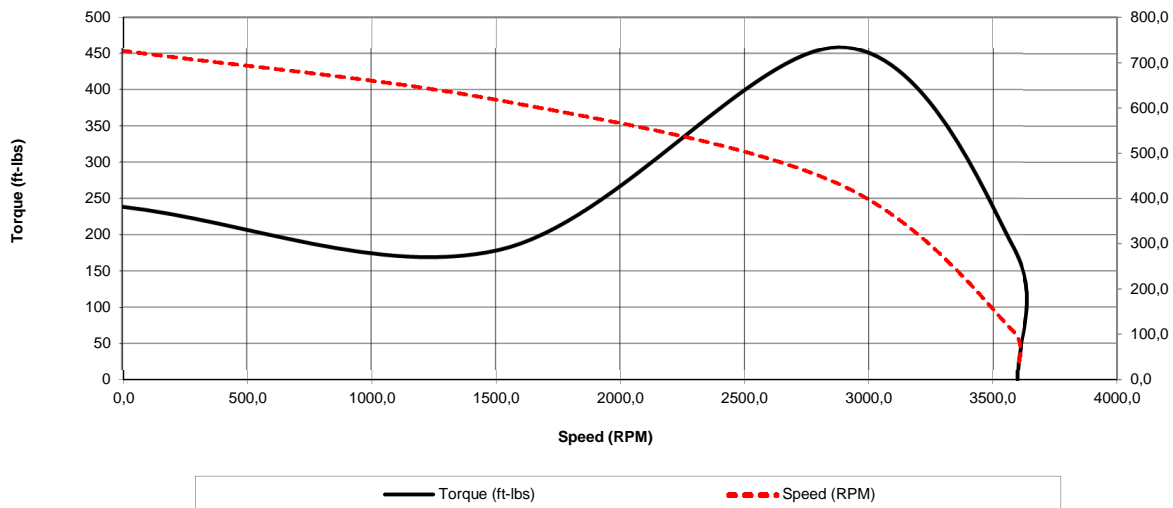

Motor Torque Capability vs RPM

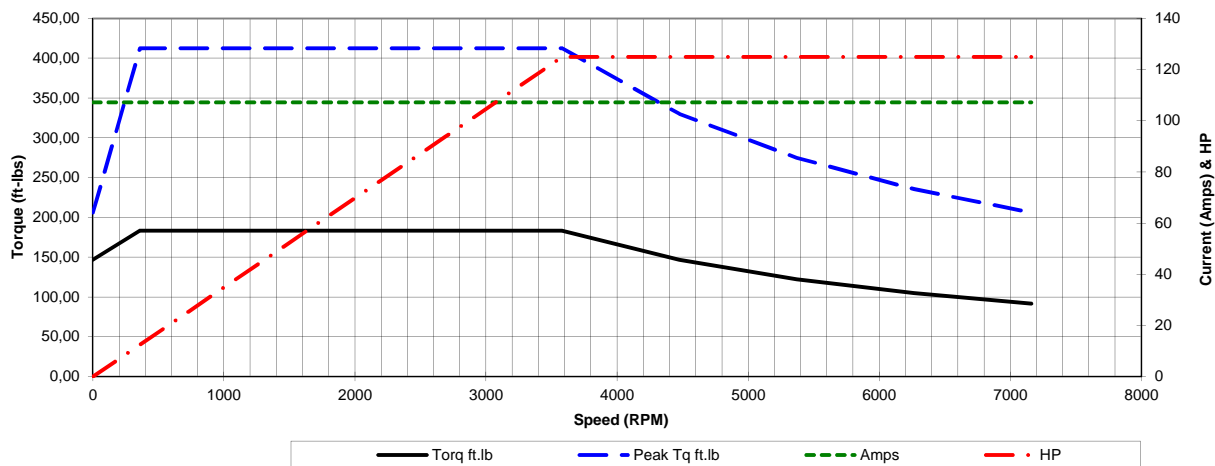



Date: 2020-02-27
 Customer: _____
 Contact: _____
 Submittee: J.C. Lavallée

Catalogue #: **MPP-81**

NEMA PREMIUM NR CAN NEMA 12 - 12										
HP	VAC	RPM	Enclosure	Frame	Frequency	Design	Poles	LR Code Letter	Insulation Class	Temp. Rise °C
125	575	3580	TEFC	444TS	60	B	2	G	F	< 80
Load %	0%	25%	50%	75%	100%	125%	150%			
Amps	26,91	38,32	58,85	82,01	107,20	133,91	163,18			
Torq ft/lbs	0	45,65	91,43	137,34	183,38	229,55	275,84			
RPM	0	3595	3590	3585	3580	3575	3570			
Eff	0	85,79	93,80	94,40	95,00	95,00	95,00			
PF	0	71,2	86	90	92	92	90,6			
	Locked Rotor	Pull-Up	Breakdown	Rated Load	Idle	Duty	S. F.	Ambient	Elevation	dBA @ 1M
Speed (RPM)	0	1512	2880	3580	3600	Continuous	1,15	40°C	3300 ft	92
Current (Amps)	726	617,1	432,0	107,2	26,9072	VFD Rating: Meets MG1 parts 31.4.4.2				
Torque (ft-lbs)	238,39	178,80	458,45	183,38	0,0	C.T.	10:1	V.T.	20:1	

